

CRIB SIZE ASSEMBLY INSTRUCTIONS:

Scan the QR code to see additional Hanging Tips on our FAQ page:

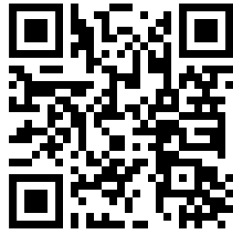



Tools Needed:

1 – Flat head screwdriver (Large)



Hardware Included:

Illustration	Part	Maggie Qty	Connie Qty	Debbie Qty	Shirley Qty
	<p>¼" NYLON WASHER</p>	18	18	18	18
	<p>¼" X 2" SS 18-8 SIDEWALK BOLT</p>	18	18	18	18
<p>ASSEMBLY INSTRUCTIONS</p>	<p>PRINTED</p>	1	1	1	1
<p>TOUCH-UP PAINT – Ordered Color</p> 	<p>.6 OZ BOTTLE</p>	1	1	1	1

Swingbed Frame Components Included:

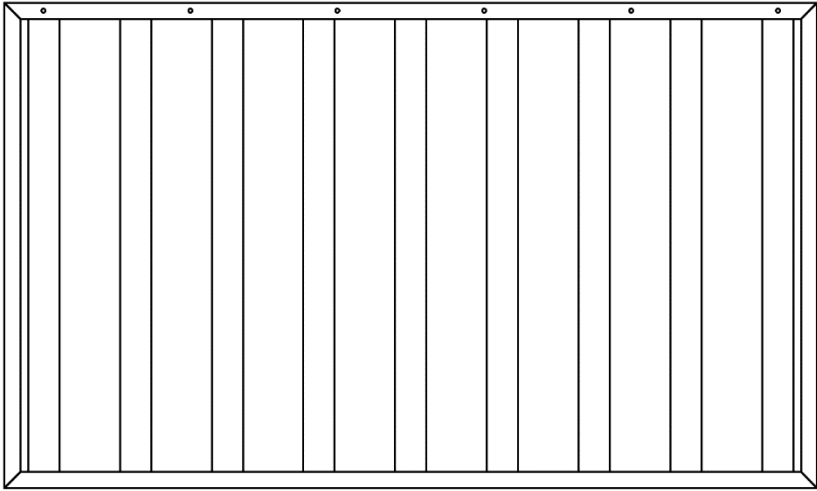
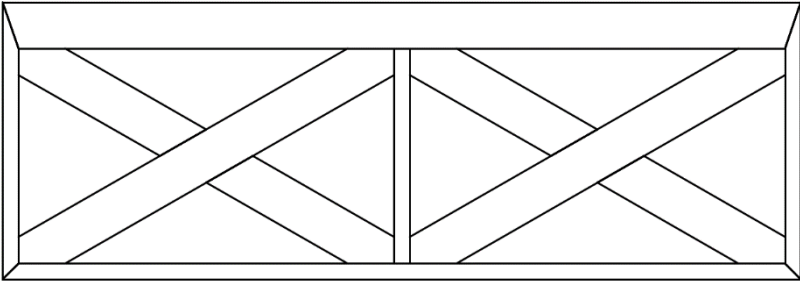
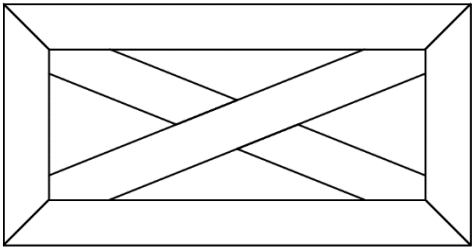
Illustration	Part	Maggie - Qty
	Seat	1
	Back	1
	Arms	2

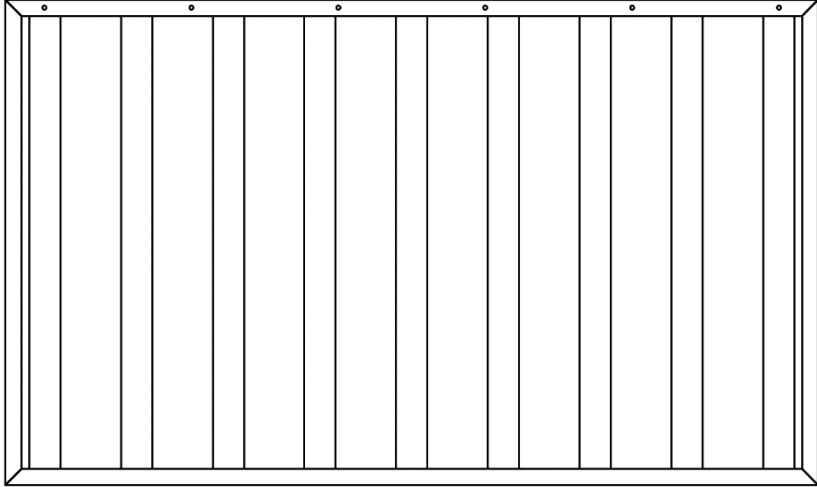
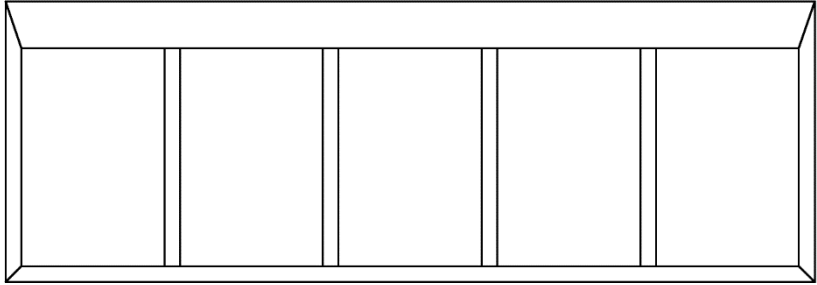
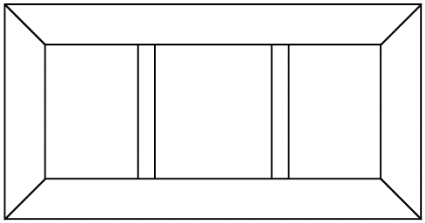

Swingbed Frame Components Included:

Illustration	Part	Connie - Qty
	Seat	1
	Back	1
	Arms	2

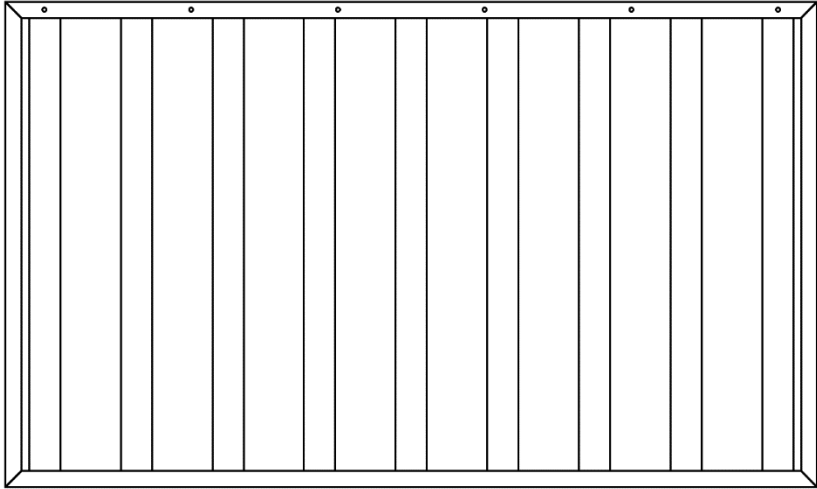
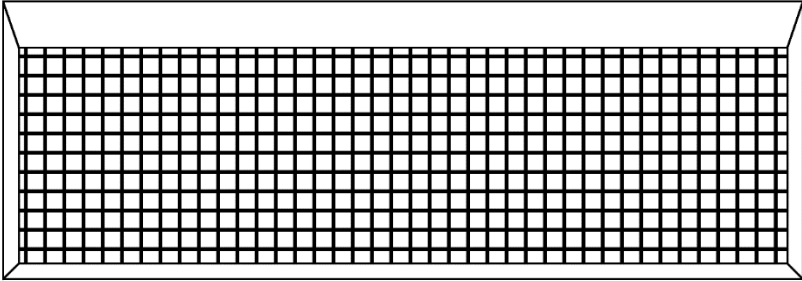
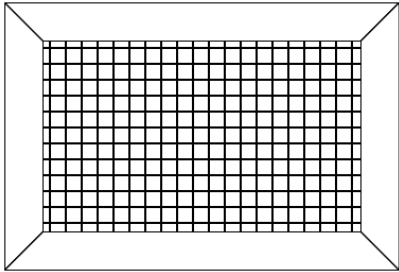
Swingbed Frame Components Included:

Illustration	Part	Debbie - Qty
	Seat	1
	Back	1
	Arms	2

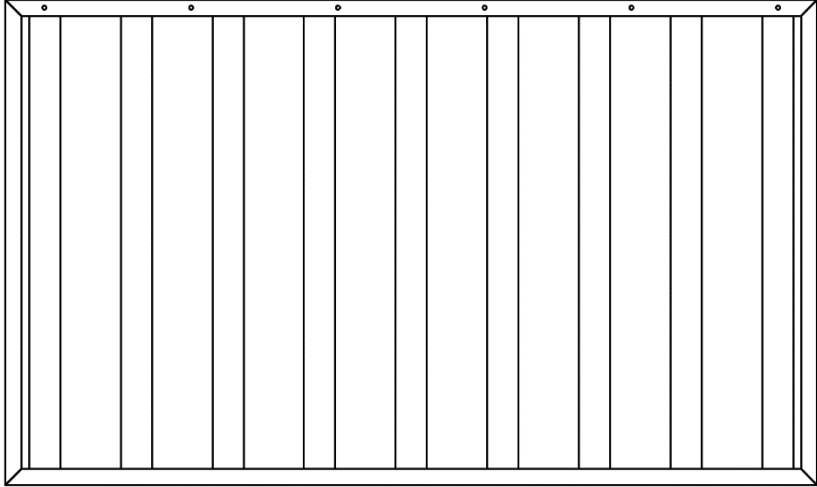
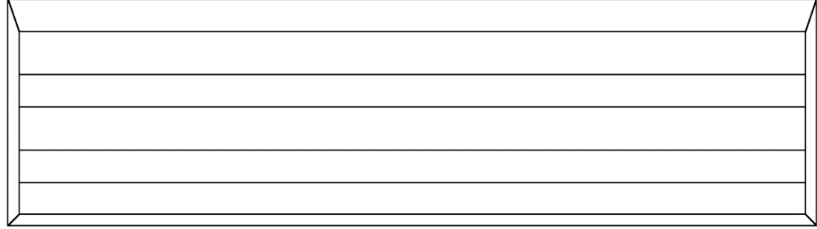
Swingbed Frame Components Included:

Illustration	Part	Shirley - Qty
	Seat	1
	Back	1
	Arms	2

ASSEMBLY NOTES:

- USE 1 NYLON WASHER WITH EACH BOLT
- DO NOT OVERTIGHTEN BOLTS
- DO NOT CRUSH NYLON WASHER
- ILLUSTRATIONS MAY NOT BE REPRESENTATIVE OF THE STYLE ORDERED

STEP 1:

LAY SEAT ON A FLAT SURFACE COVERED WITH THE SHIPPING BOX (OR SOMETHING SIMILAR) TO ELIMINATE DAMAGE DURING ASSEMBLY

STEP 2:

SET BACK ON SEAT BY ALIGNING CONNECTION HOLES

STEP 3:

USING 2" *SIDEWALK BOLTS AND WASHERS* (Qty 6 ea), **LOOSELY** SECURE THE BACK PANEL TO THE SEAT ON THE BOTTOM ONLY. FINISH UP BY TIGHTENING ALL BOLTS TO FIRMLY SECURE THE 2 PIECES TOGETHER.

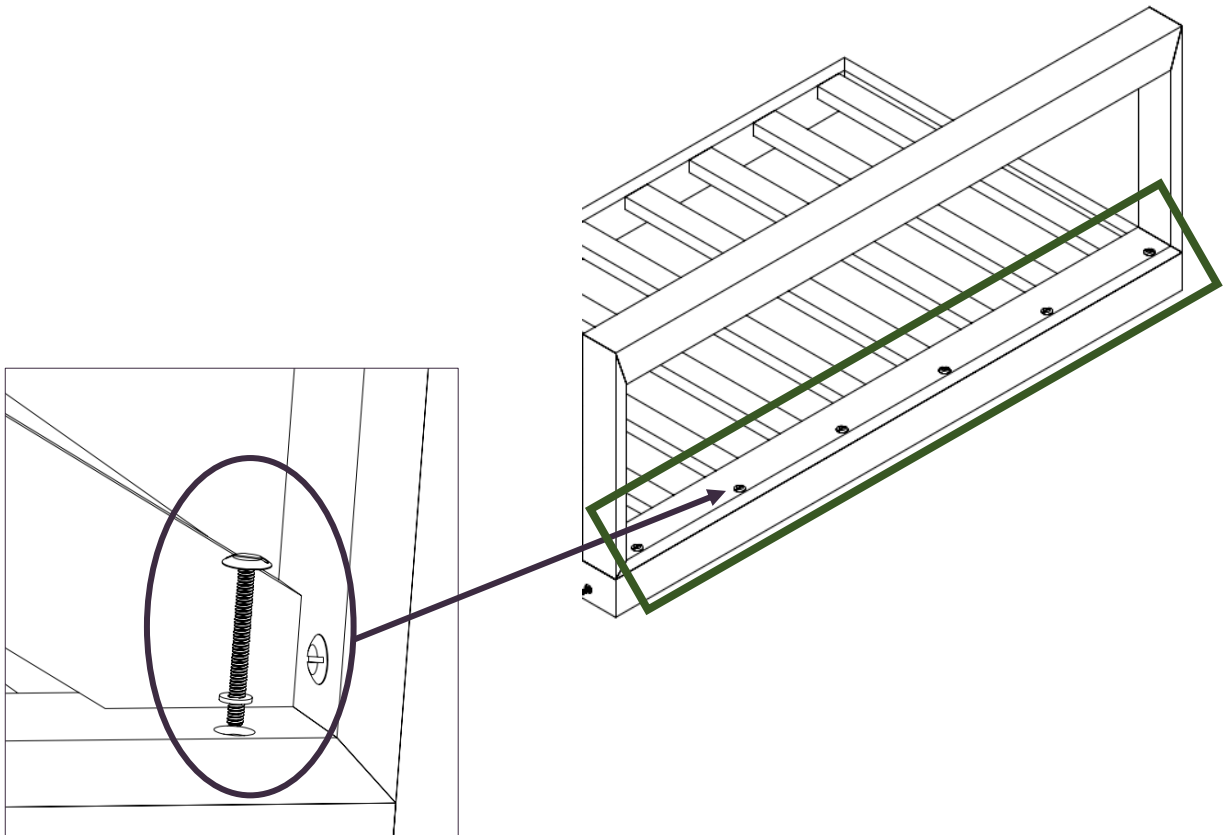

STEP 4:

USING 2" SIDEWALK BOLTS AND WASHERS (QTY 2 ON EACH SIDE), **LOOSELY** SECURE ONE (1) SIDE ARM PANEL TO THE BACK PANEL. PROCEED WITH THE OTHER SIDE ARM PANEL.

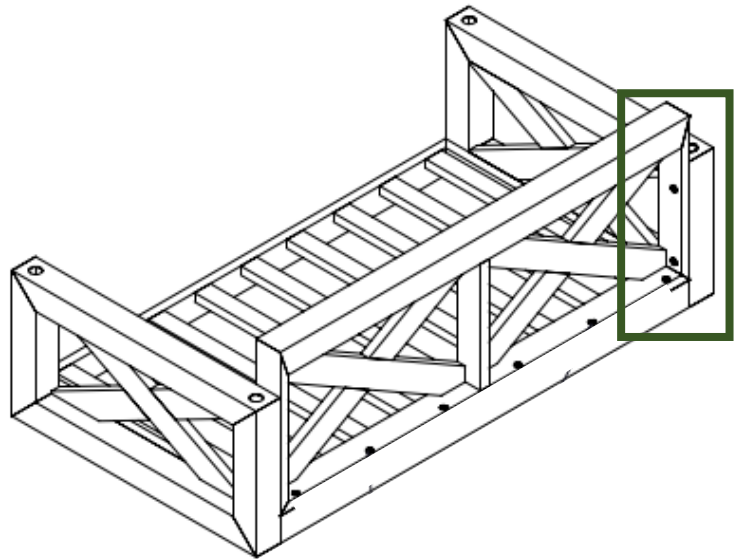

STEP 5:

LAY THE SWING ON IT'S BACK AND **LOOSELY** SECURE BOTH SIDE ARM PANELS TO THE SEAT FRAME USING 2" SIDEWALK BOLTS AND WASHERS (QTY 4 ON EACH ARM).

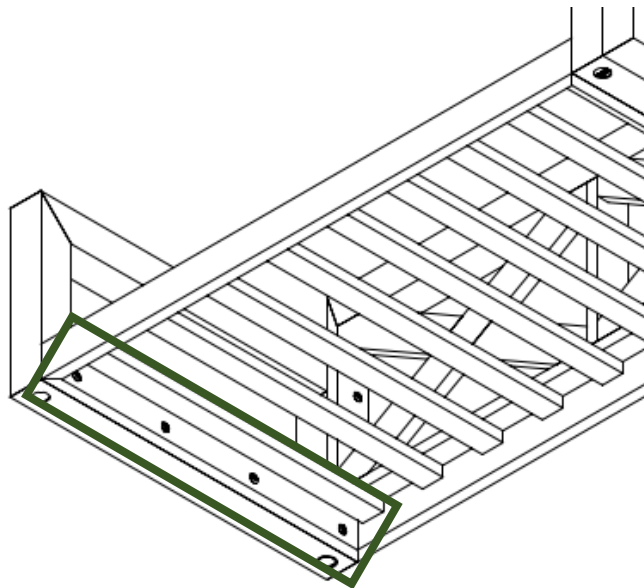

STEP 6:

TIGHTEN ALL BOLTS ON THE SWING BOTTOM AS SHOWN IN STEP 5, THEN SET THE SWING BACK UP TO FINISH SECURING THE ARMS.

STEP 7:

FINISH TIGHTENING BOLTS ON BOTH ARM SIDE PANELS CONNECTING TO THE BACK PANEL.

NOTE: DO NOT OVERTIGHTEN BOLTS

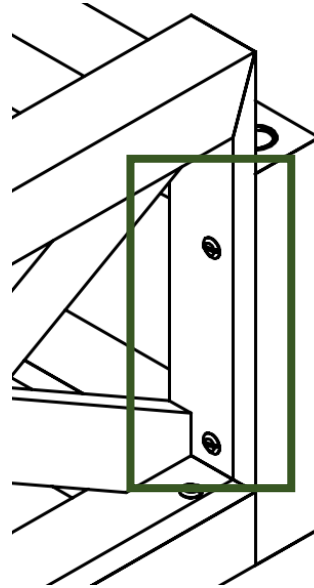

YOUR SWING IS NOW READY FOR HANGING HARDWARE AND INSTALLATION!

Let us hear from you!

support@havenandharmony.com

727.597.4142

